

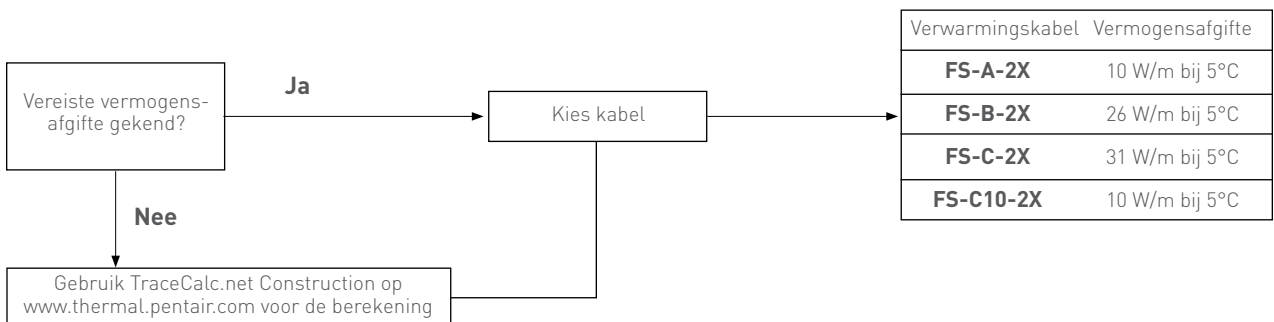

Raychem OVERZICHT ONTWERP: VORSTBEVEILIGINGSSYSTEMEN VOOR LEIDINGEN

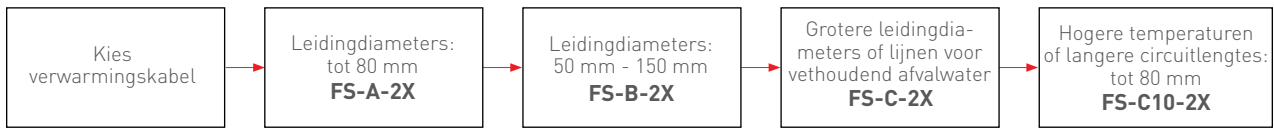

Elektrische veiligheid en beveiligingsapparatuur circuits → Aardlekschakelaar 30 mA 100 ms vereist

Teken verwarmingscircuits, rekening houdend met de maximale circuitlengte voor de verwarming de vereiste vermogensdichtheid.

Max. circuitlengte 230 Vac (Opstarten bij 0°C)				
Stroomonderbreker (Type C)	FS-A-2X	FS-B-2X	FS-C-2X	FS-C10-2X
4 A	45 m	25 m	20 m	45 m
6 A	70 m	35 m	30 m	70 m
10 A	110 m	65 m	55 m	110 m
13 A	130 m	85 m	70 m	130 m
16 A	150 m	105 m	90 m	150 m
20 A	-	-	-	180 m

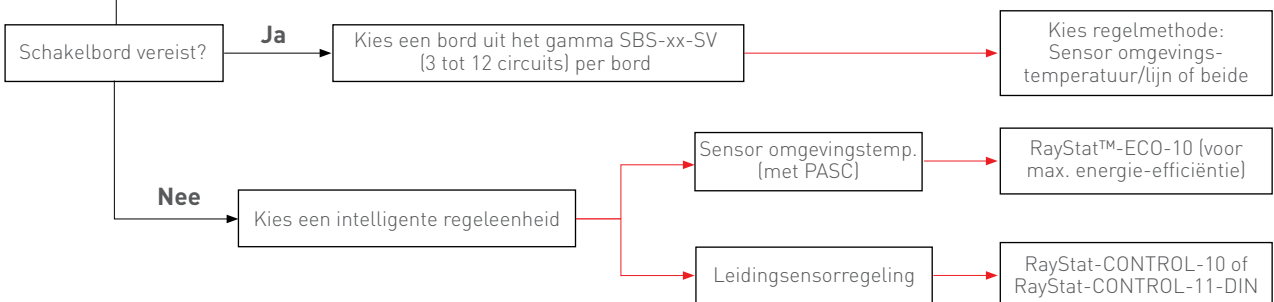
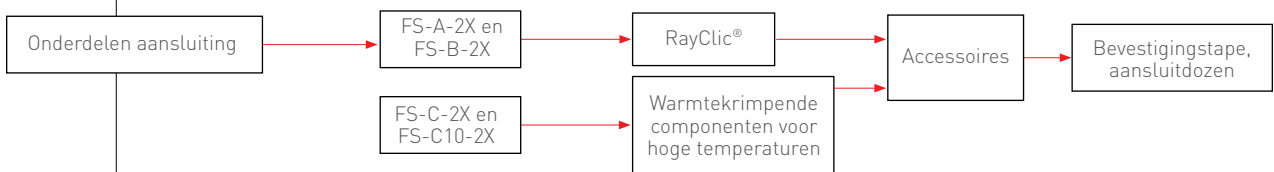



WWW.THERMAL.PENTAIR.COM

BELGIË

Tel. 016 21 35 02
Fax 016 21 36 04
salesbelux@pentair.com

NEDERLAND

Tel. 0800 0224978
Fax 0800 0224993
salesnl@pentair.com

All Pentair trademarks and logos are owned by Pentair. All other brand or product names are trademarks or registered marks of their respective owners. Because we are continuously improving our products and services, Pentair reserves the right to change specifications without prior notice. Pentair is an equal opportunity employer.

© 2013 Pentair. All Rights Reserved.