



PRESSURE RELIEF PORTS 2224-2226



Wall or ceiling mounted pressure relief vent for cold rooms up to 2700 ft³ - Patented



- Extends in depth from 2 ¼ to 4 ¾ inches (up to 7 ¾ inches with the aluminium extension tube)
- Easy mounting
- Increased air-flow

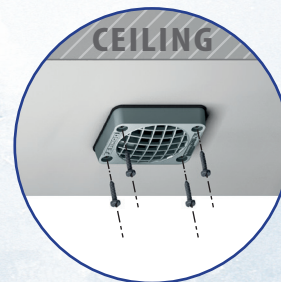
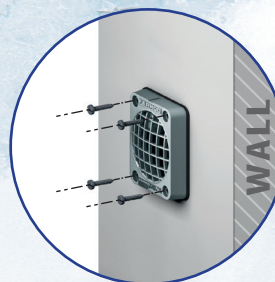

Wall or ceiling mount

The walls of a cold room are constantly subjected to strains caused by pressure variations, either from inside or outside. The patented FERMOD pressure relief vents allow the balance of internal and external pressures.

TWO REFERENCES:



Wall or ceiling mounted vent with heating cord, 10W continuous power, **only for negative temperature cold room** down to -22°F (-30°C).

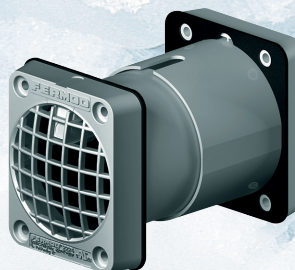

Wall or ceiling mounted vent without heating cord, **for positive temperature cold room** up to 180°F (80°C).

THREE POSSIBLE OPTIONS FOR THE CABLE OUTLET:

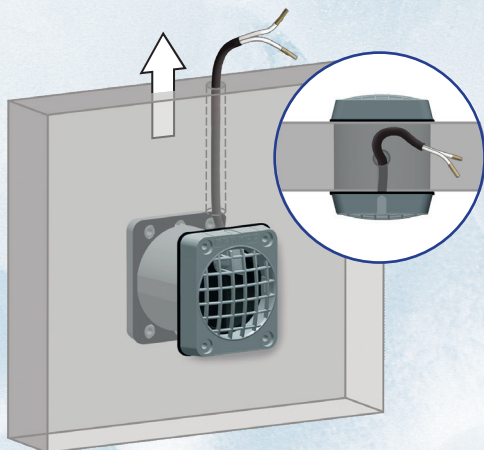

Through the panel
2224-M

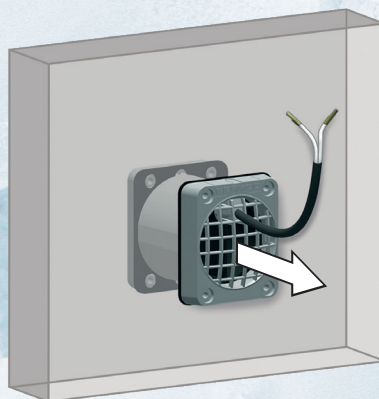

Horizontal, external to the panel
2224-H

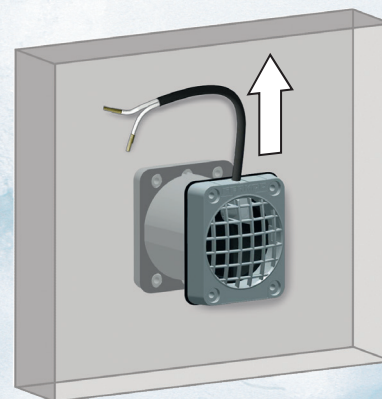

Vertical, external to the panel
2224-V



PRESSURE RELIEF PORTS 2224-2226



Wall or ceiling mounted pressure relief vent for cold rooms up to 2700 ft³ - Patented

DESCRIPTION OF THE VENT:

- Expandable vent : one size fits all—from 2 ¼ inches to 4 ¾ inches wall thickness and up to 7 ¾ inches with the aluminium extension tube
- For 4 ¾ inches maximum ceiling thickness
- 3 possible options for the cable outlet: external/vertical to the panel or through the panel
- Wall or ceiling mounting
- 28% increase in flow compared with the market-leading competitor
- Fermod vent saves significant mount time vs the competition
- Airtight mobile flaps to limit ice formation in cold room
- Watertight mounting to avoid ice formation between the valve and the wall
- 10W heating element is completely encapsulated in the vent
- Rust free
- Made of chemically resistant composite material
- The 2224 and 2226 vents are Recognized under the Component Recognition Program of UL according to the following standards: UL 471 & CSA C22.2 N° 120

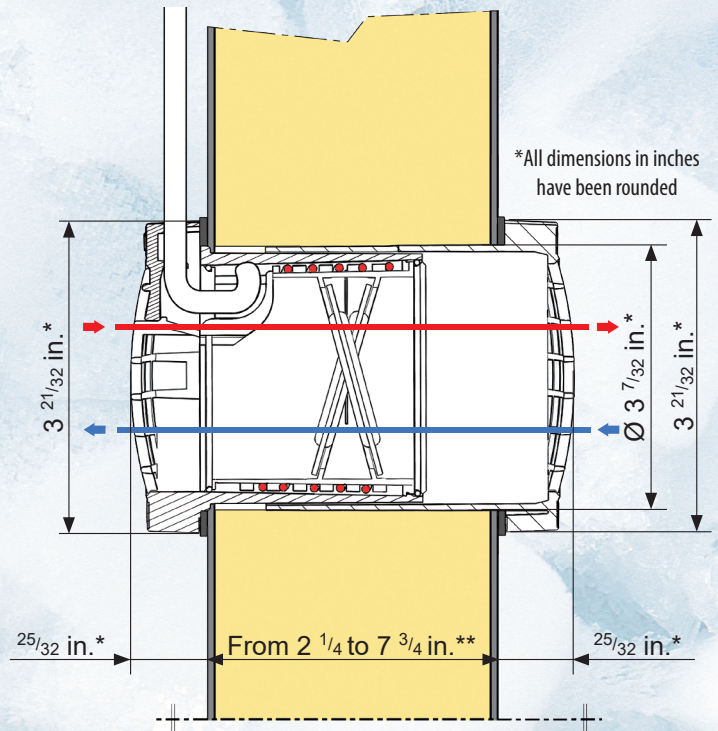

** Standard dimension: from 2 ¼ to 4 ¾ in.
Up to 7 ¾ in. with the optional aluminium connection tube

HOW TO DETERMINE THE NUMBER OF VENTS REQUIRED ?

The following formula determines the number of vents needed for a given case:

V = Volume of the room in ft³

T = Time variation in min. for 1°F

t = Temperature of the room in °F

459 / 0.127 / 0.156 = constant values

- For a maximum evenly distributed pressure of **300 Pa** (1.2 in. H2O pressure):

$$\text{Number of vents} = \frac{0.127 V}{T(459 + t)}$$

Example : $V = 2700 \text{ ft}^3 / T = 1 \text{ minute for } 1^\circ\text{F} / t = -13^\circ\text{F}$

$$\text{Number of vents} = \frac{0.127 \times 2700}{1(459-13)} = 0.77 = \sim 1 \text{ vent}$$

If the data used for calculation are exactly observed, our vents ensure that the maximum evenly distributed pressure is not exceeded.

(The application and the result of the formulas are dependent on the initial data being correct.)



FERMOD®



3 avenue Eugène Gazeau - 60300 SENLIS - FRANCE
 Tél. : +33 (0)3 44 53 12 86 - Fax : +33 (0)3 44 53 62 03
 www.fermod.com • e-mail: contact@fermod.com
 Siège Social : Senlis (Oise) - Société Anonyme au Capital de 1 004 400 €
 RCS Compiègne B 301 468 211 - Siret 301 468 211 00018 - APE 2572 Z

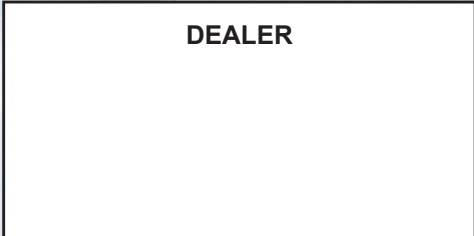

2021-10