



Manual systems for sliding doors up to 200, 300 and 400 kg Patented



Fermatic 3500-400Kg
For sliding doors up to 400 Kg

Fermatic 3500-300Kg / 7500-300Kg
For sliding doors up to 300 Kg

Fermatic 3500 / 7500
For sliding doors up to 200 Kg

All rails are patented. The mobile part of each system is located inside the track which also acts as a cover and simplifies the maintenance.

The rails **3500** and **7500** are interchangeable.

5 manual systems:

- **3530 Steel rail / 7530 Stainless Steel rail:** for doors up to 200 Kg maxi, with lever handle
- **3530-300Kg Steel rail / 7530-300Kg Stainless Steel rail:** for doors up to 300 Kg maxi, with lever handle
- **3530-400Kg Steel rail:** for doors up to 400 Kg maxi, with lever handle
- The rail 3500 is made of zinc-passivated **Steel** (20 microns)
- The rail 7500 is made of **Stainless Steel** AISI 304L, specially recommended for use in salty and corrosive atmosphere, like dairys, meat...
- The mobile parts of 3500 and 7500 are made of Anodized Aluminium (**Duralinox**)

A complete range for doors up to 6240 mm width:

	Door width (in mm)							
	840 to 1140	1141 to 1440	1441 to 1740	1741 to 2040	2041 to 2340	2341 to 2640	2641 to 2940	2941 to 3240
200 Kg*	3531/7531	3532/7532	3533/7533	3534/7534	3535/7535	3536/7536	3537/7537	3538/7538
300 Kg*	3531-300Kg 7531-300Kg	3532-300Kg 7532-300Kg	3533-300Kg 7533-300Kg	3534-300Kg 7534-300Kg	3535-300Kg 7535-300Kg	3536-300Kg 7536-300Kg	3537-300Kg 7537-300Kg	3538-300Kg 7538-300Kg
	2040 to 2340	2341 to 2640	2641 to 3240	3241 to 3840	3841 to 4440	4441 to 5040	5041 to 5640	5641 to 6240
400 Kg*	3535-400Kg	3536-400Kg	3538-400Kg	3539-400Kg	3540-400Kg	3541-400Kg	3542-400Kg	3543-400Kg

*Maximum door weight

10/2022

« In order to improve the quality of our products, FERMOD reserve the right to modify any products without notice. The characteristics and pictures of the products presented on this documentation are not of any legal value.»



FERMATIC 3500 / 7500 for doors up to 200 Kg maxi



Features and advantages:

- Pleasing appearance and excellent hygiene properties are achieved by the rail concealing the mechanical components
- Systems **3500** and **7500** can be mounted using the same fixing spacings
- Robustness, top quality sealing
- Easy mounting and adjustments
- Easy stocking due to symmetrical design (right or left hand)
- Easy and smooth operation
- Minimum overlap on top of the door
- Operating temperature range: -30°C to +55°C
- Products in accordance to the UKCA/European Directives and Standards

Accessories

- Internal and external lever handles, face or edge-fixing
- Internal fixed handle
- Gaskets

Options

- Locks 37/38, 57/57HP+, 58/58HP+
- PVC cover



Wall guiding system 7540



Automatic Kit 5010 for 3530 / 7530 with motor 370W

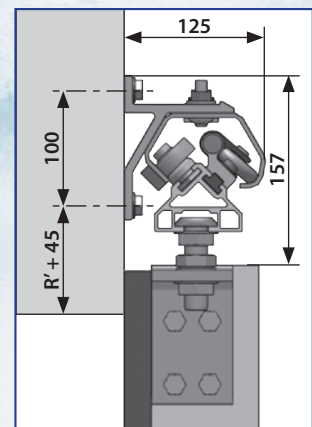
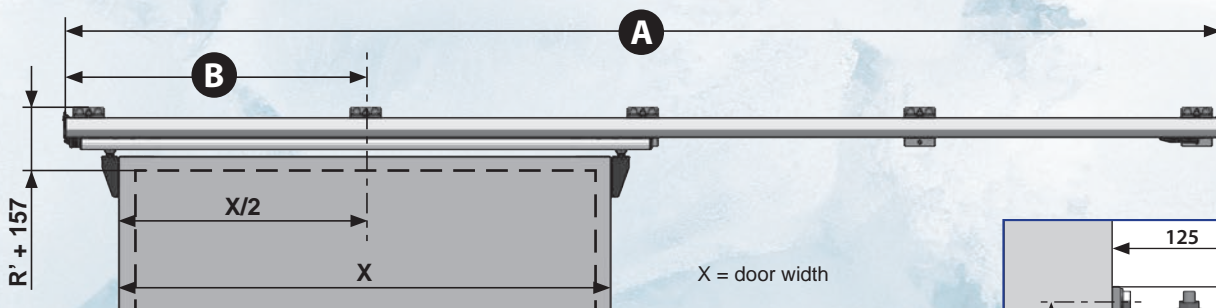

References	Door width	A	B
3531/7531	840 to 1140 mm	2550	675
3532/7532	1141 to 1440 mm	3150	825
3533/7533	1441 to 1740 mm	3750	975
3534/7534	1741 to 2040 mm	4350	1125
3535/7535	2041 to 2340 mm	4950	1275
3536/7536	2341 to 2640 mm	5550	1425
3537/7537	2641 to 2940 mm	6150	1575
3538/7538	2941 to 3240 mm	6750	1725



FERMATIC 3500-300Kg / 7500-300Kg for doors up to 300 Kg maxi

Fermatic 3530-300Kg: with rail made of zinc-passivated Steel

Fermatic 7530-300Kg: with rail made of Stainless Steel AISI 304L

Features and advantages:

- Same mounting as systems 3500/7500 for doors up to 200 Kg
- Strengthening parts for rail, double swivel rollers and more rail brackets for a greater robustness
- Rail concealing the mechanical components for excellent hygiene properties
- Mobile part made of Anodized Aluminium (Duralinox)
- Operating temperature range: -30°C to +55°C
- Products in accordance to the UKCA/European Directives and Standards

Accessories

- Extended external and internal handles 7530 set to suit extra weight
- Gaskets

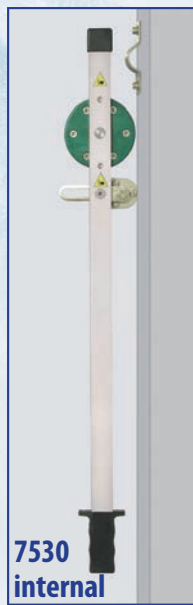
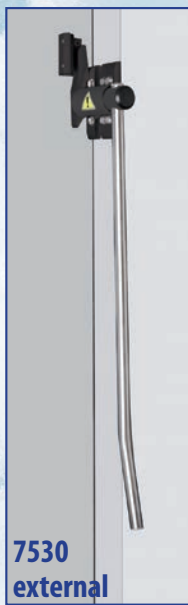

Options

- Locks 37/38
- PVC cover



Automatic Kit 5000
for 3530 -300Kg / 7530-300Kg
with motor 550W

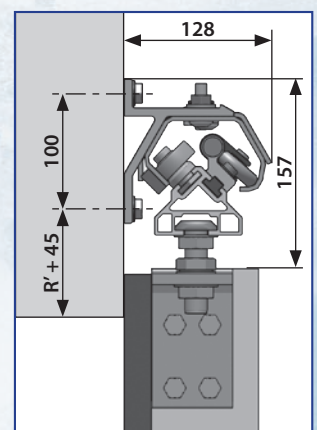
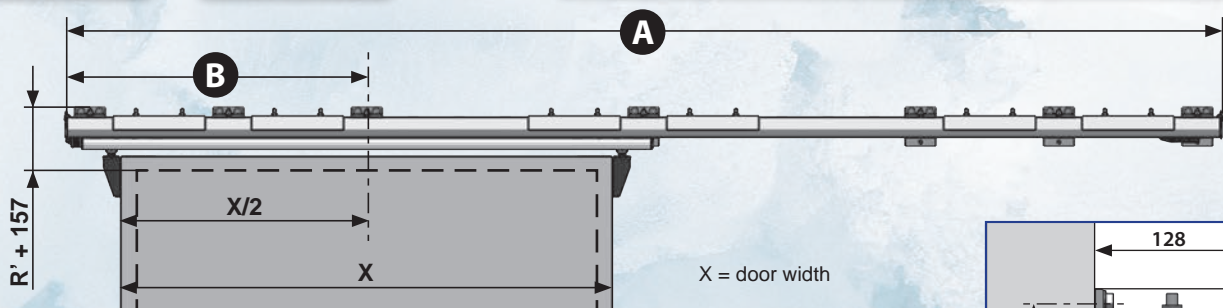

References	Door width	A	B
3531-300Kg/7531-300Kg	840 to 1140 mm	2550	675
3532-300Kg/7532-300Kg	1141 to 1440 mm	3150	825
3533-300Kg/7533-300Kg	1441 to 1740 mm	3750	975
3534-300Kg/7534-300Kg	1741 to 2040 mm	4350	1125
3535-300Kg/7531-300Kg	2041 to 2340 mm	4950	1275
3536-300Kg/7536-300Kg	2341 to 2640 mm	5550	1425
3537-300Kg/7537-300Kg	2641 to 2940 mm	6150	1575
3538-300Kg/7538-300Kg	2941 to 3240 mm	6750	1725



FERMATIC 3500-400Kg for doors up to 400 Kg maxi

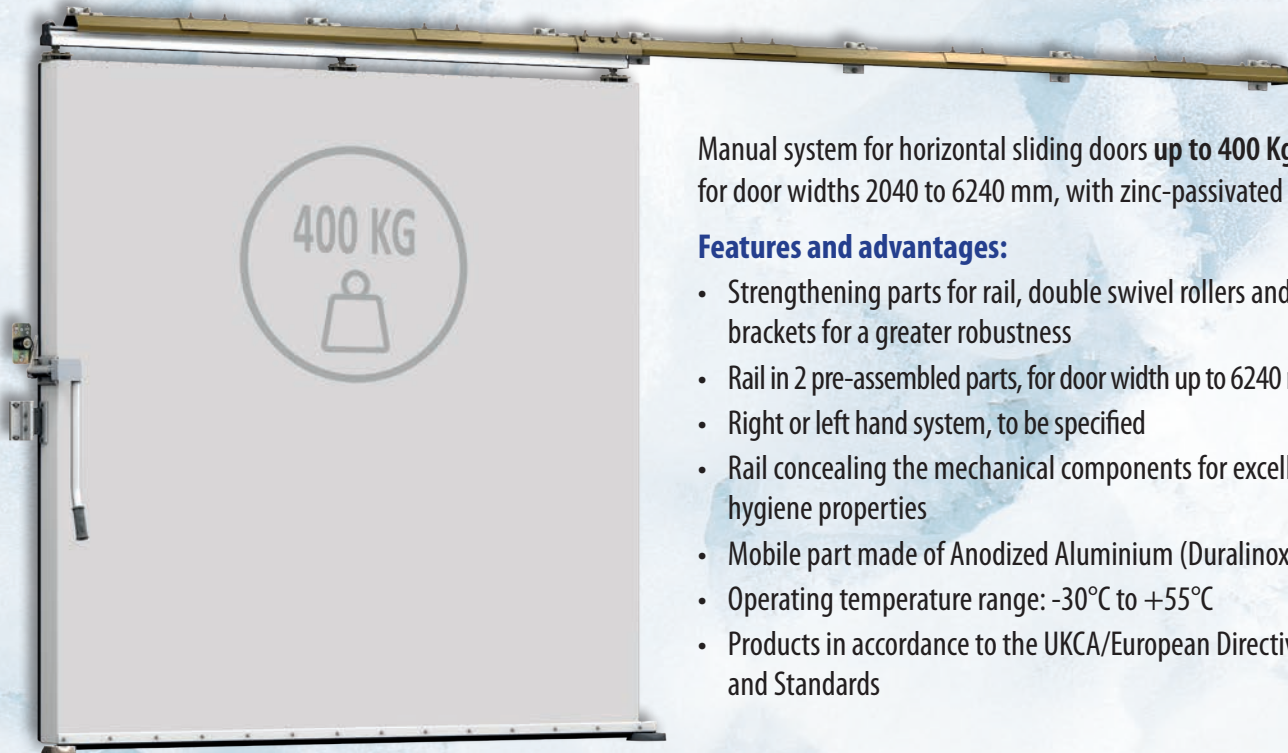

Manual system for horizontal sliding doors **up to 400 Kg**, suitable for door widths 2040 to 6240 mm, with zinc-passivated Steel rail.

Features and advantages:

- Strengthening parts for rail, double swivel rollers and more rail brackets for a greater robustness
- Rail in 2 pre-assembled parts, for door width up to 6240 mm
- Right or left hand system, to be specified
- Rail concealing the mechanical components for excellent hygiene properties
- Mobile part made of Anodized Aluminium (Duralinox)
- Operating temperature range: -30°C to +55°C
- Products in accordance to the UKCA/European Directives and Standards

Accessories

- Internal and external lever handles, edge-fixing
- Gaskets

Options

- Locks 37/38

Automatic Kit 5400
for system 3530-400Kg
with motor 750W

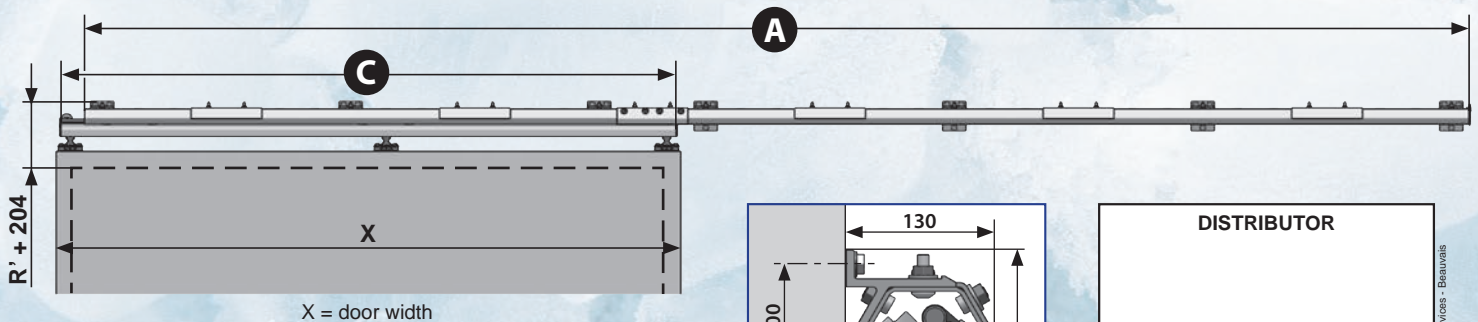
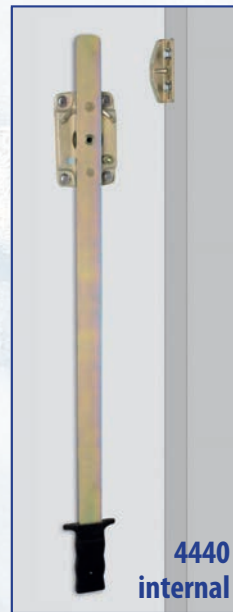

References	Door width	A	C
3535-400Kg	2040 to 2340 mm	4650	2000
3536-400Kg	2341 to 2640 mm	5250	2300
3538-400Kg	2641 to 3240 mm	5850	2600
3539-400Kg	3241 to 3840 mm	7050	3200
3540-400Kg	3841 to 4440 mm	8250	3800
3541-400Kg	4441 to 5040 mm	9450	4400
3542-400Kg	5041 to 5640 mm	10650	5000
3543-400Kg	5641 to 6240 mm	11850	5600

DISTRIBUTOR

10/2022



FERMOD

3 avenue Eugène Gazeau - 60300 SENLIS - FRANCE
Tél. : +33 (0)3 44 53 12 86 - Fax : +33 (0)3 44 53 62 03
www.fermod.com - e-mail: contact@fermod.com
Siège Social : Senlis (Oise) - Société Anonyme au Capital de 1 004 400 €
RCS Compiegne B 301 468 211 - Siret 301 468 211 00018 - APE 2572 Z